

**DESIGN AND TECHNOLOGY**

9705/13

Paper 1

October/November 2018

3 hours

Additional Materials: Answer Booklet/A4 Paper  
A3 Drawing Paper (2 sheets)  
Extra sheets of A3 drawing paper for candidates who have used up both sides of their 2 sheets  
A range of design drawing equipment

**READ THESE INSTRUCTIONS FIRST**

If you have been given an Answer Booklet, follow the instructions on the front cover of the Booklet.  
Write your name, Centre number and candidate number on all the work you hand in.

Write in dark blue or black pen.

You may use an HB pencil, or coloured pencils/pens as appropriate, for any diagrams, graphs or rough working.

Do not use staples, paper clips, glue or correction fluid.

DO **NOT** WRITE IN ANY BARCODES.

**Section A**

Answer **one** question on the Answer Booklet/A4 Paper provided.

**Section B**

Answer **one** question on the Answer Booklet/A4 Paper provided.

**Section C**

Answer **one** question on plain A3 paper.

Use **both** sides of the paper.

You may request additional sheets of A3 paper, but only if you have used up both sides of each of the 2 sheets provided.

You are advised to spend **30 minutes** on each of Sections A and B and **2 hours** on Section C.

At the end of the examination, fasten all your work securely together.

The number of marks is given in brackets [ ] at the end of each question or part question.

All dimensions are in millimetres.

This document consists of **16** printed pages.

Section A

Answer **one** question from this section on the Answer Booklet/A4 paper provided.

- 1 Fig. 1 gives details about a table lamp that is to be made in a school workshop.

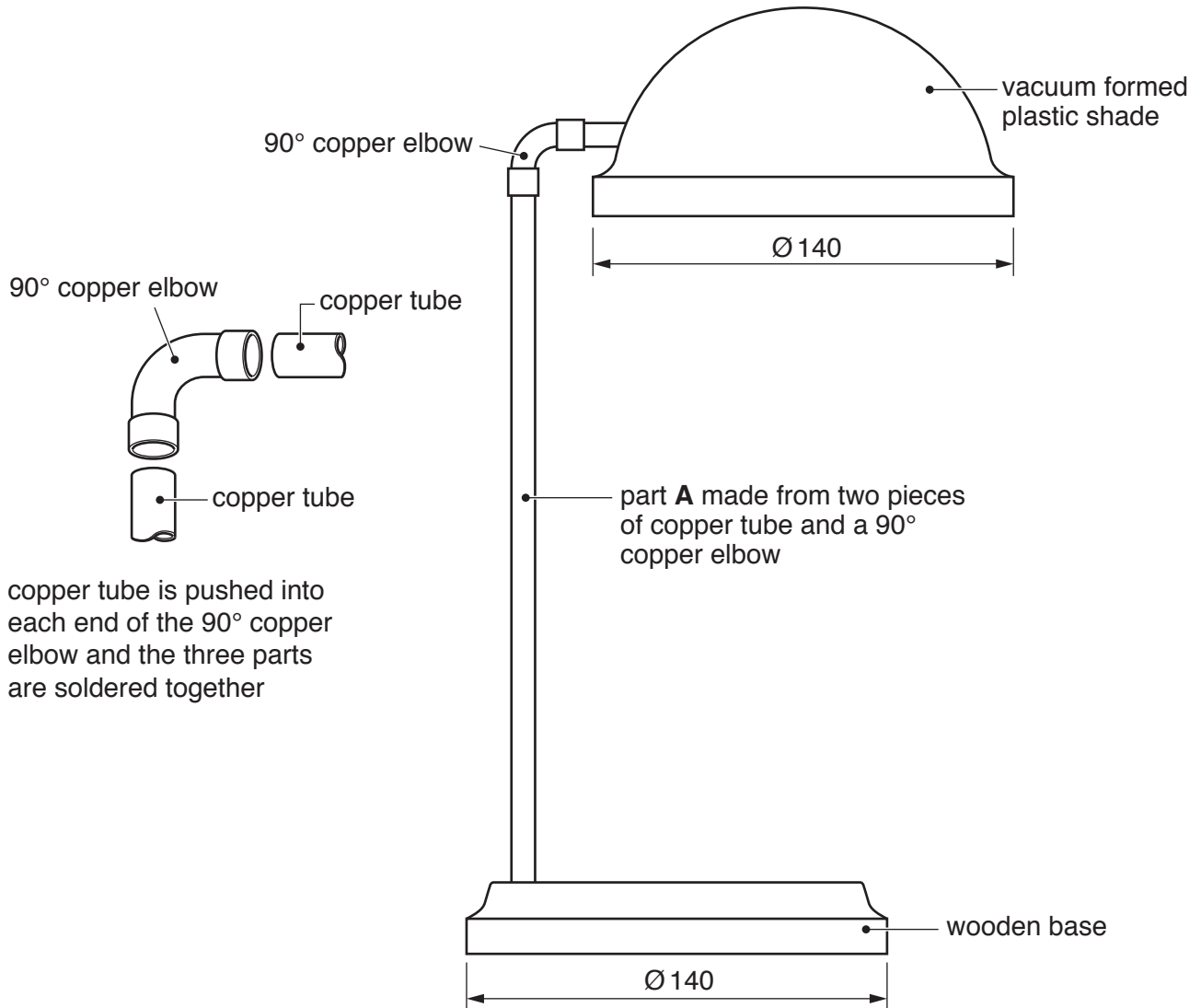
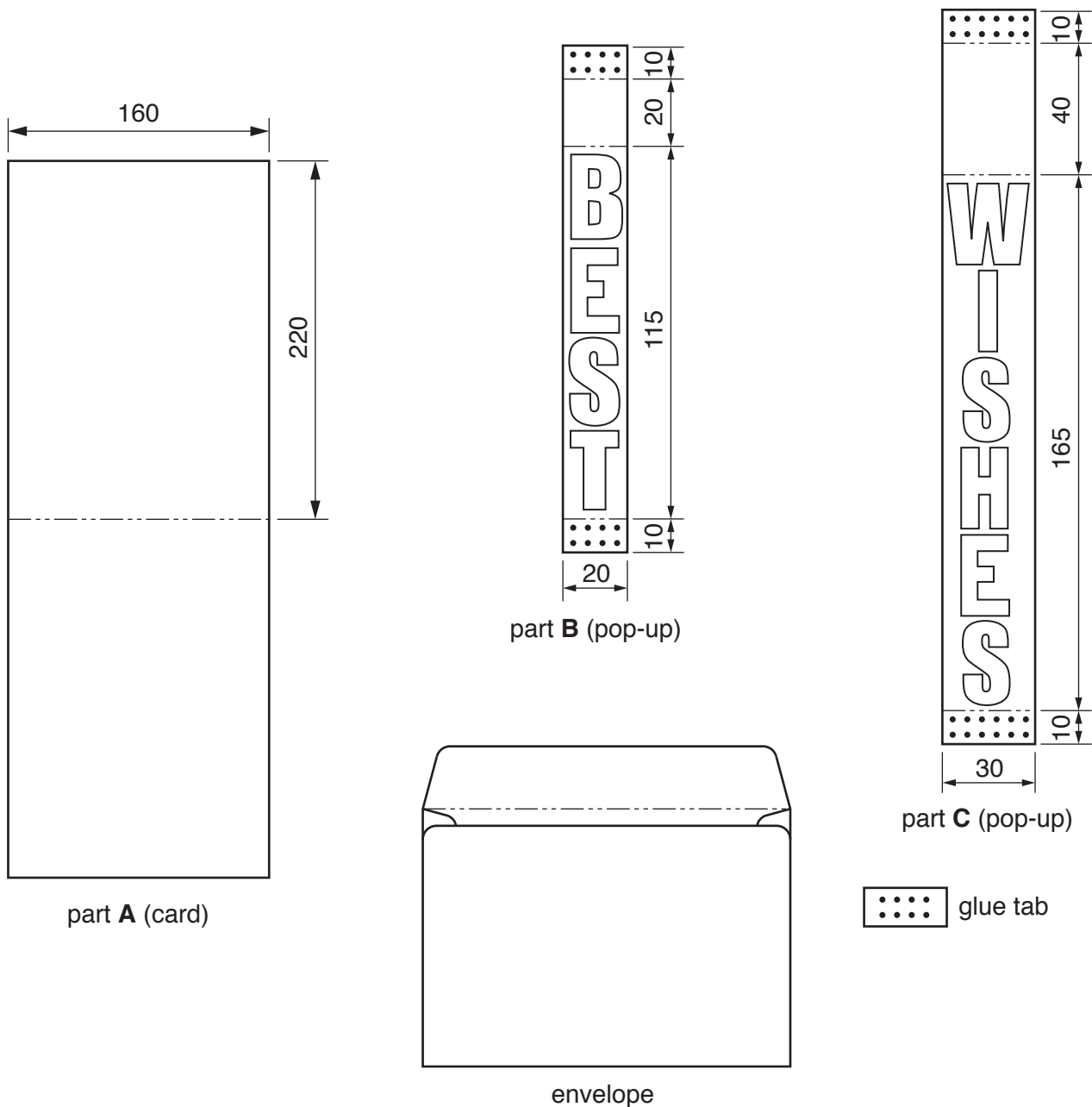

Fig. 1

- (a) Name a suitable plastic for making the shade and give **one** reason for your choice. [2]
- (b) Use notes and sketches to describe:
- (i) how the shade could be vacuum formed; [6]
  - (ii) how the base could be made on a lathe; [6]
  - (iii) how the three parts required to make part **A** could be soldered together. [6]

You must give details about the tools, equipment and processes involved and the safety precautions that have to be undertaken at each stage.

- 2 Fig. 2 gives details about a pop-up card and an envelope that are to be made in a school workshop.

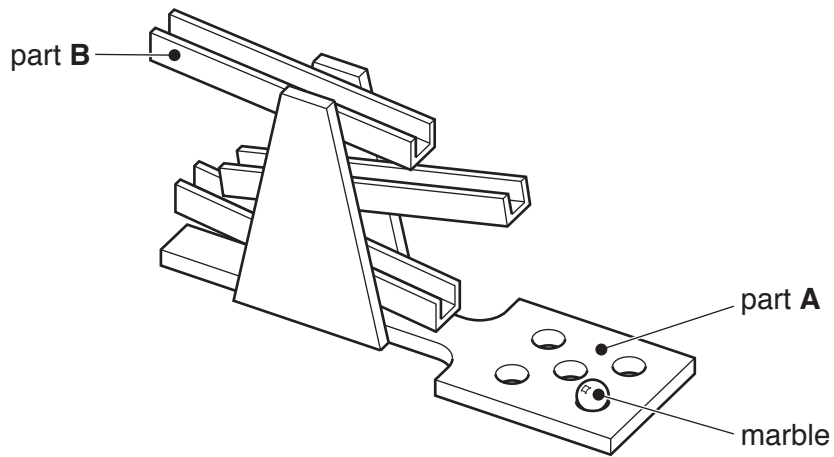

**Fig. 2**

- (a) State an appropriate size for the envelope that will hold the card. [2]
- (b) Using notes and sketches produce a stage by stage work plan for making the envelope. [6]
- (c) Produce a fully dimensioned drawing of part **A** that shows exactly where the glue tabs on parts **B** and **C** will need to be fixed. [6]
- (d) Sketch a pictorial (3D) view of the assembled card when open. Do **not** include the lettering in this view. [6]

You must give details about the tools, equipment and processes involved and the safety precautions that have to be undertaken at each stage.

- 3 Fig. 3 gives details about a marble game, made from wood, which is to be produced in a school workshop.



assembled view of marble game

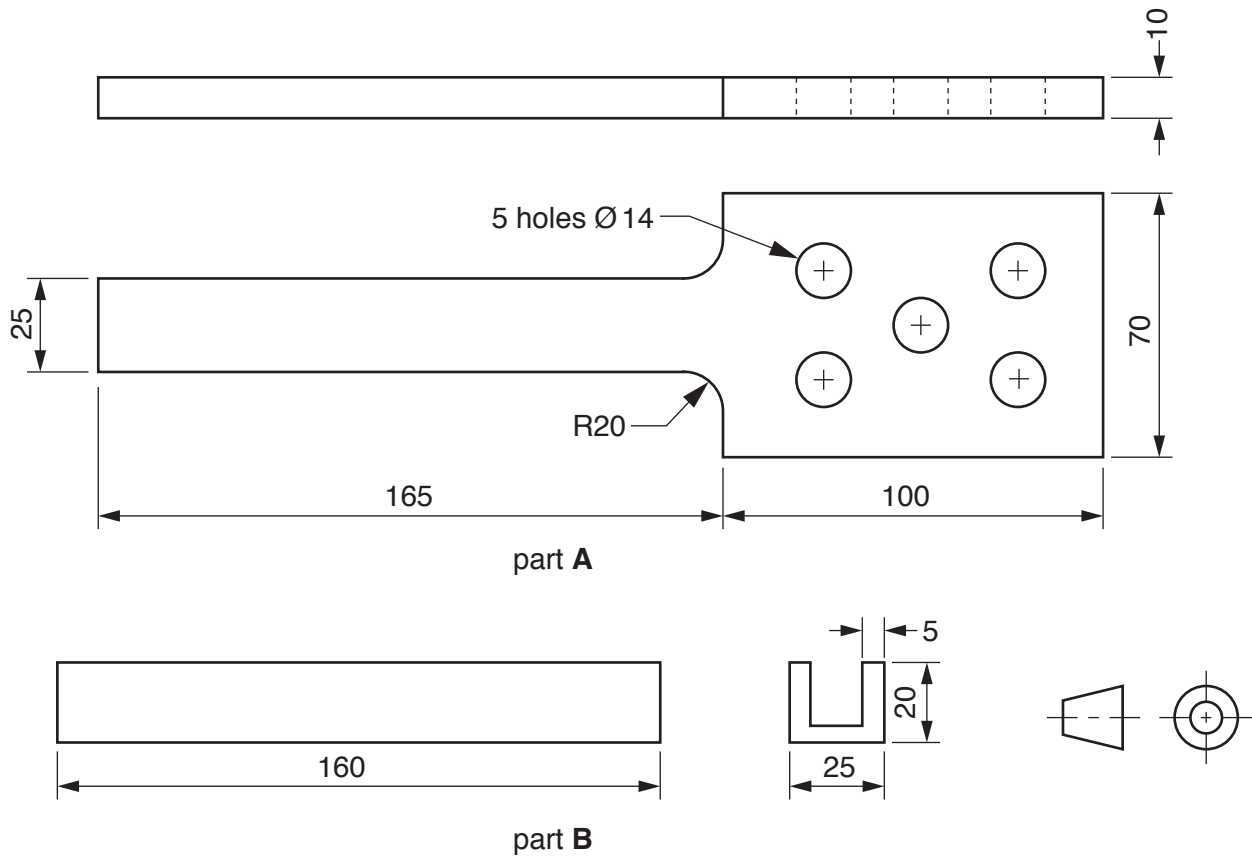

Fig. 3

- (a) A non-toxic finish will be applied to the completed game.  
Explain what is meant by a **non-toxic finish**. [2]
- (b) Use notes and sketches to describe:
- (i) how part **A** could be made; [6]
  - (ii) how part **B** could be made; [6]
  - (iii) how the six parts could be joined together using panel pins and glue. [6]

You must give details about the tools, equipment and processes involved and the safety precautions that have to be undertaken at each stage.

## Section B

Answer **one** question from this section on the Answer Booklet/A4 paper provided.

- 4 Fig. 4 gives details about a modular storage unit that can be arranged in various combinations as illustrated. The symbols shown are ones that many manufacturers place on their products.

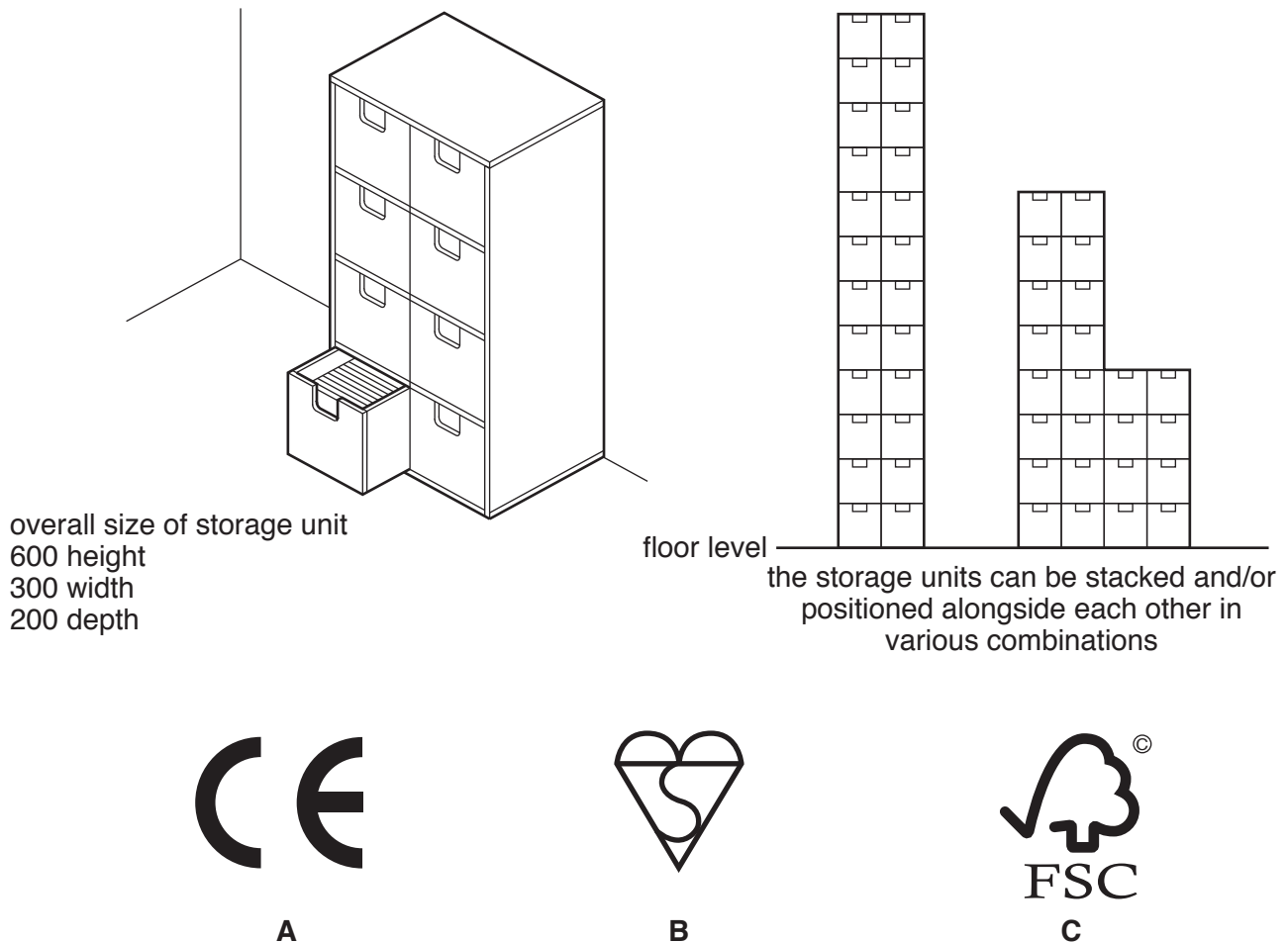

Fig. 4

- (a) Select **one** of the symbols **and** explain what it means. [2]
- (b) Tests carried out on the storage unit have shown that it is unsafe when used in the combinations shown in Fig. 4.  
Identify **and** describe **two** problems with the design of the storage unit that make it unsafe. [4]
- (c) Using notes and sketches, explain how the design would need to be changed to overcome the two problems you have identified in part (b). [6]

- (d) Discuss how **and** why, when developing new products, companies need to consider the protection and rights of consumers.

Your answer should:

- (i) analyse the given situation **and** identify **three** relevant issues raised by the question; [3]
- (ii) explain why you consider these issues to be relevant; [3]
- (iii) contain specific examples/evidence to support your conclusions. [2]

- 5 Fig. 5 gives details about packaging, made from card, to hold the DVD and booklet shown. The plastic sticker keeps the packaging securely closed prior to purchase.

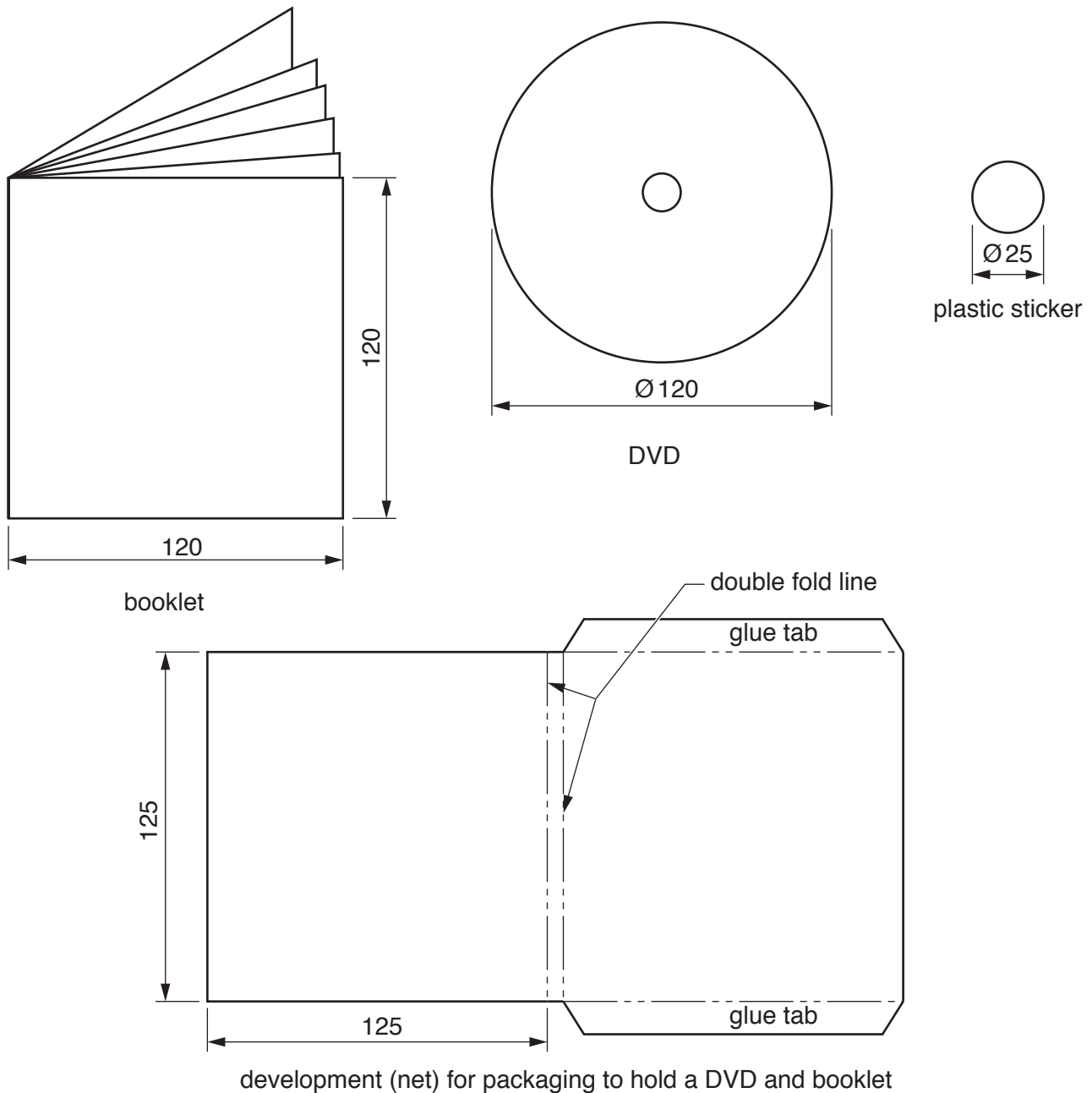

Fig. 5

- (a) Explain the function of the double fold line shown on the development (net). [2]
- (b) Identify **and** describe **two** problems with the design of the development (net). [4]
- (c) Using notes and sketches, explain how the design of the development (net) would need to be changed to overcome the two problems you have identified in part (b). [6]



- (d) Discuss the effectiveness of various security methods currently used to prevent packaging being tampered with prior to purchase.

Your answer should:

- (i) analyse the given situation **and** identify **three** relevant issues raised by the question; [3]
- (ii) explain why you consider these issues to be relevant; [3]
- (iii) contain specific examples/evidence to support your conclusions. [2]

- 6 Fig. 6 shows a cut-away diagram of a fluidising tank used in the process of dip coating metal with plastic.

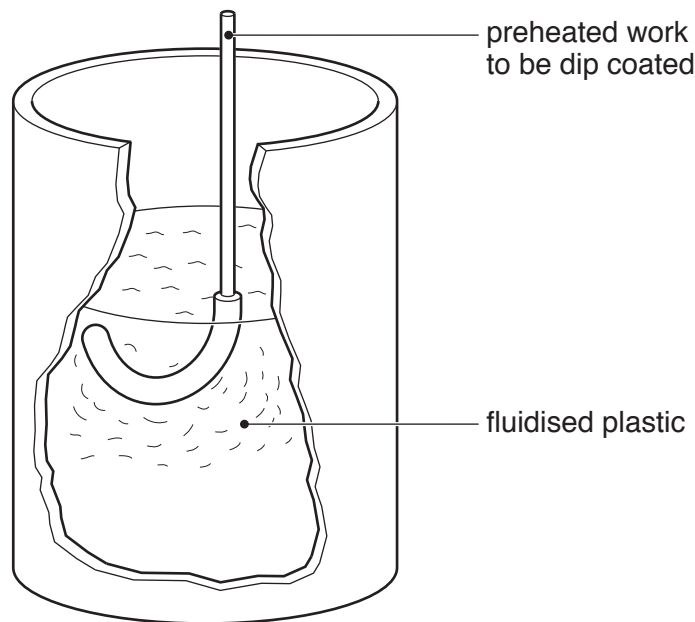

**Fig. 6**

- (a) Explain why the metal has to be preheated before it is put in the tank. [2]
- (b) Identify **and** describe **two** problems with the design. [4]
- (c) Using notes and sketches, explain how the diagram would need to be changed to overcome the two problems you have identified in part (b). [6]

Fig. 7 shows a range of finishes used on wood.

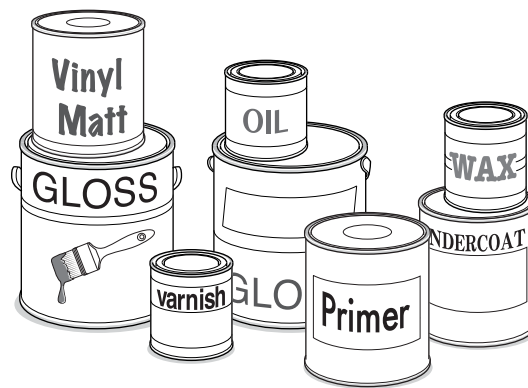

**Fig. 7**

- (d)** Discuss why the production and use of water based rather than spirit or oil based paints, varnishes, wood stains and dyes has increased in recent years.

Your answer should:

- (i)** analyse the given situation **and** identify **three** relevant issues raised by the question; [3]
- (ii)** explain why you consider these issues to be relevant; [3]
- (iii)** contain specific examples/evidence to support your conclusions. [2]

## Section C

Answer **one** question from this section on the plain A3 paper provided.

You are provided with two sheets of plain A3 paper. You should use **both** sides of the paper. **Each** of the four **parts (a)–(d)** of the question you choose to answer should take up one side of paper.

When you are asked to **develop** a design you must show, using notes and sketches, the development and evaluation of a **range** of ideas into a single design proposal. The design proposal should be annotated to give details about materials, joining methods and important sizes.

- 7 Fig. 8 shows an incomplete idea for a display stand. A number of these stands will be used to display paintings at an art exhibition.

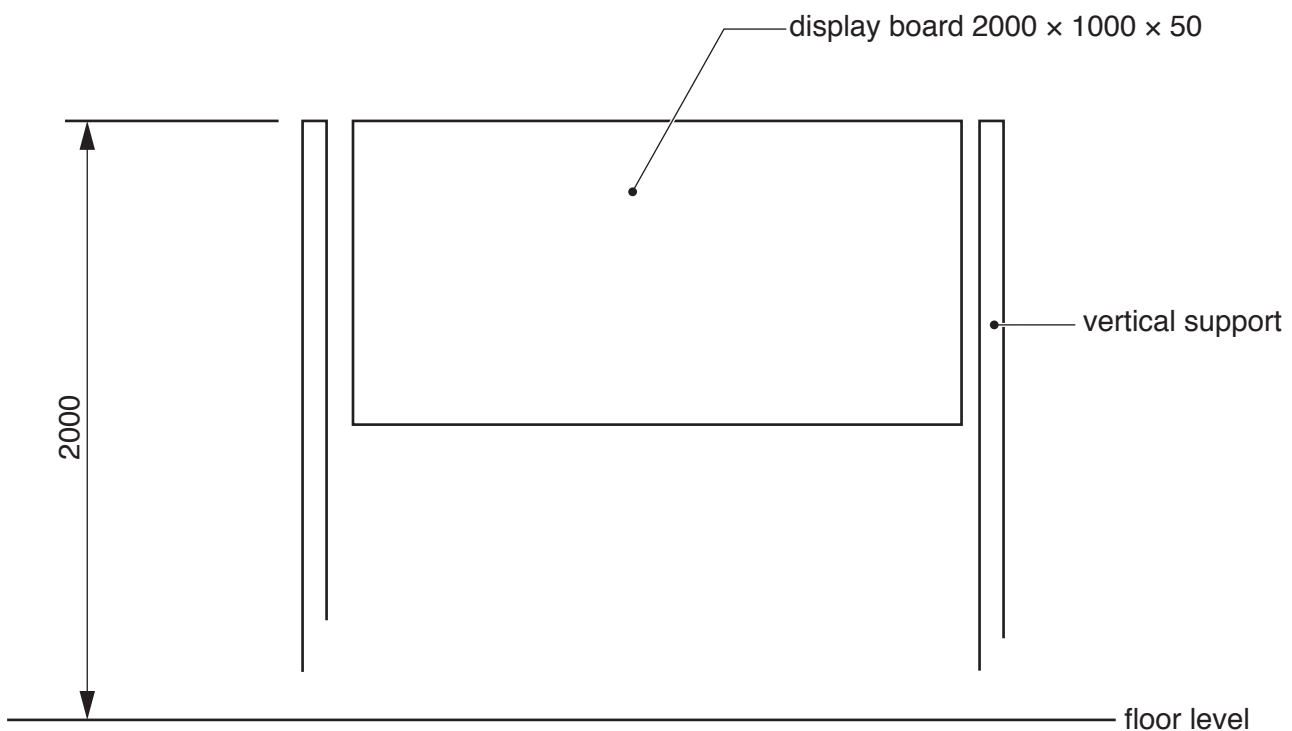

**Fig. 8**

- (a) Using notes and sketches, **develop** a design for a stable base for the vertical supports. This must include a method of securely joining the base to each support but allows it to be easily removed for storage purposes. [20]
- (b) Using notes and sketches, **develop** a design for the display board. This must include a method of securely joining the display board to the vertical supports but allows it to be easily removed for storage purposes. [20]
- (c) Using notes and sketches, **develop** a design for a holder for A4 sized catalogues giving information about the paintings on display. The design must include a method of attaching the holder to the display stand which allows it to be easily removed for storage purposes. [20]
- (d) Produce a pictorial rendered drawing of the complete display stand which shows all of the features that you have designed in parts (a)–(c). [20]

**TURN OVER FOR QUESTION 8**

8 Fig. 9 shows the contents of a board game and an incomplete idea for packaging the game. The packaging consists of three parts:

- a square tray made from card;
- a plastic, vacuum formed insert that fits in the card tray and holds the contents of the board game;
- a lid for the packaging, made from card, which fits over the square tray.

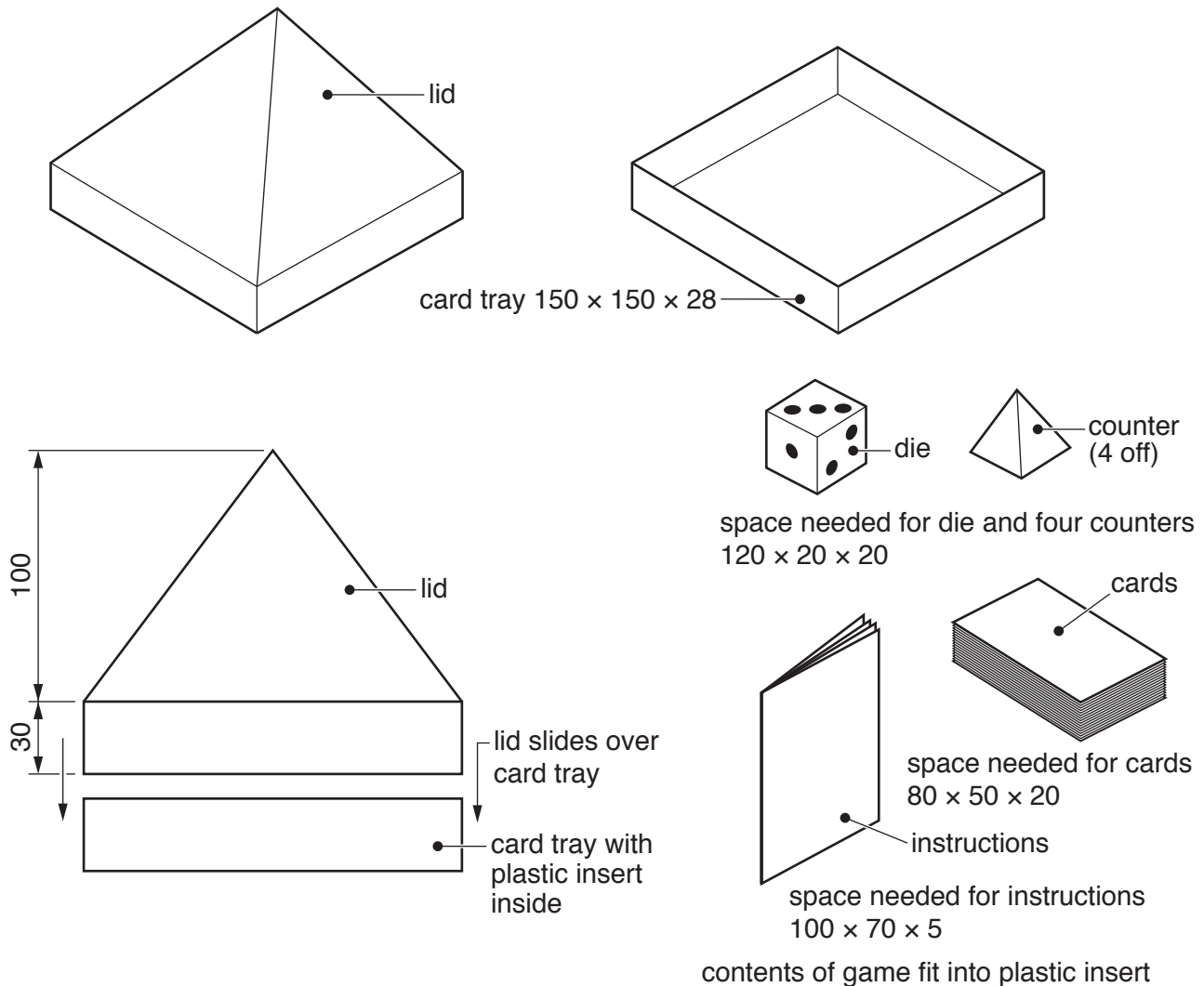

**Fig. 9**

(a) Using notes and sketches, **develop** designs for:

- the card tray. Your design work must include details of the one piece development (net) required to make the tray;
- the plastic insert. [20]

(b) Using notes and sketches, **develop** a design for the lid. This must include a method of joining the lid to the card tray that allows the packaging to be easily opened and closed. Your design work must include details of the one piece development (net) required to make the lid. [20]

- (c) Using notes and sketches, **develop** a design for the lettering to go on the packaging. The name of the game is '**The Phantom of the Pyramid**' and the lettering should be in a style that reflects the name. [20]
- (d) Produce an exploded, pictorial, rendered drawing of the complete packaging that shows all of the features that you have designed in parts (a)–(c).  
Do **not** include the contents of the game in this drawing. [20]

- 9 Fig. 10 shows an incomplete design for modular bedroom furniture that combines a wardrobe, a storage unit with adjustable shelves and a seat with storage for shoes.

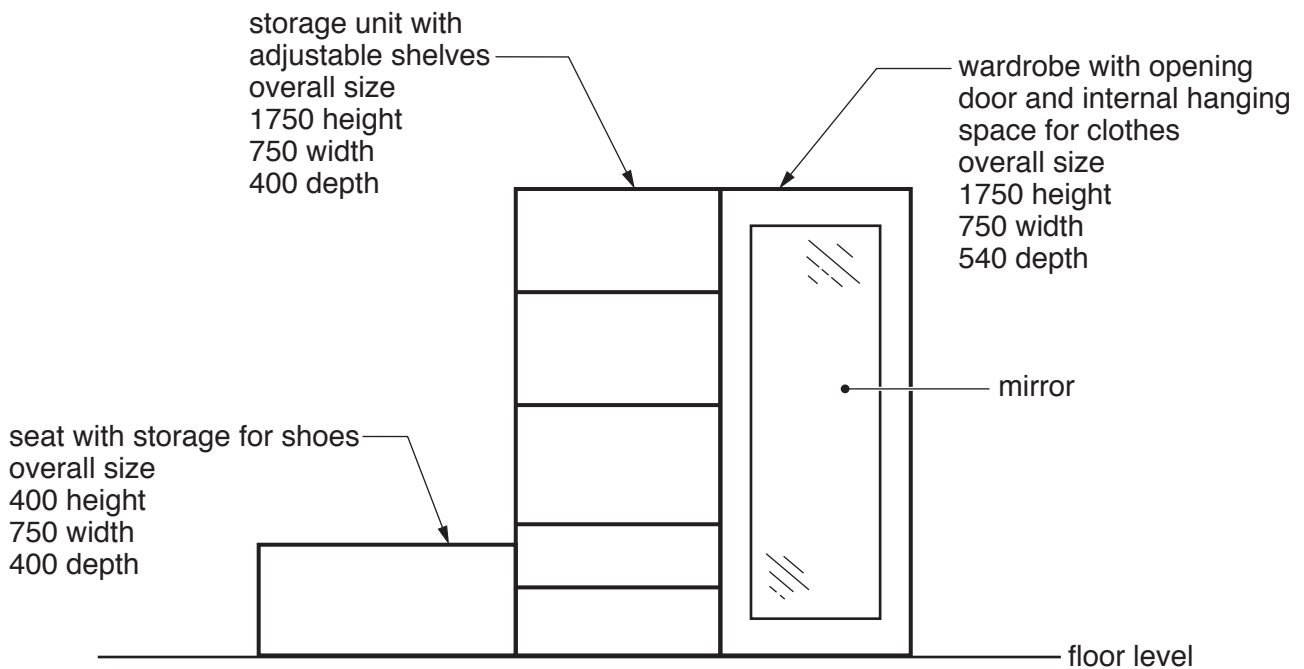

**Fig. 10**

- (a) Using notes and sketches, **develop** a design for the wardrobe. This must include a method of hanging clothes inside the wardrobe. [20]
- (b) Using notes and sketches, **develop** a design for the storage unit. This must include a method that allows the position of the shelves to be changed. [20]
- (c) Using notes and sketches, **develop** a design for the seat. This must include a facility for storing shoes. [20]
- (d) Produce a pictorial rendered drawing of the complete bedroom furniture that shows all of the features that you have designed in parts (a)–(c). The wardrobe door should be shown open in this view. [20]

Permission to reproduce items where third-party owned material protected by copyright is included has been sought and cleared where possible. Every reasonable effort has been made by the publisher (UCLES) to trace copyright holders, but if any items requiring clearance have unwittingly been included, the publisher will be pleased to make amends at the earliest possible opportunity.

To avoid the issue of disclosure of answer-related information to candidates, all copyright acknowledgements are reproduced online in the Cambridge International Examinations Copyright Acknowledgements Booklet. This is produced for each series of examinations and is freely available to download at [www.cie.org.uk](http://www.cie.org.uk) after the live examination series.

Cambridge International Examinations is part of the Cambridge Assessment Group. Cambridge Assessment is the brand name of University of Cambridge Local Examinations Syndicate (UCLES), which is itself a department of the University of Cambridge.