



UNIVERSITY OF CAMBRIDGE INTERNATIONAL EXAMINATIONS
General Certificate of Education
Advanced Subsidiary Level and Advanced Level

DESIGN AND TECHNOLOGY

9705/33

Paper 3

October/November 2012

3 hours

Additional Materials: Answer Booklet/Paper
A range of design drawing equipment
A3 Drawing paper (5 sheets)

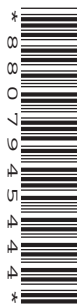

READ THESE INSTRUCTIONS FIRST

Write your Centre number, candidate number and name on all the work you hand in.
Write in dark blue or black pen.
You may use a soft pencil for any diagrams, graphs or rough working.
Do not use staples, paper clips, highlighters, glue or correction fluid.

Section A

Answer any **two** questions from **one** of the Parts **A**, **B** or **C**.

Section B

Answer **one** question.

All dimensions are in millimetres.

The instruction 'discuss' denotes that you should:

- examine critically the issues raised by the question;
- explain and interpret these issues as appropriate;
- introduce evidence wherever possible to support conclusions of arguments.

At the end of the examination, fasten all your work securely together.

The number of marks is given in brackets [] at the end of each question or part question.

This document consists of **10** printed pages and **2** blank pages.



Section A

Answer **two** questions from **one** of the Parts A, B or C.

Part A – Product Design

1

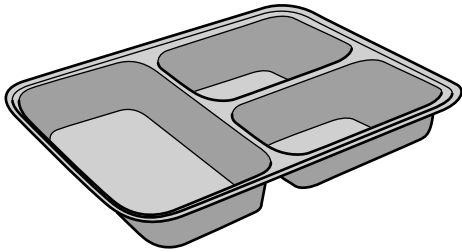

item: tray
process: vacuum forming

item: face plate
process: drilling and boring

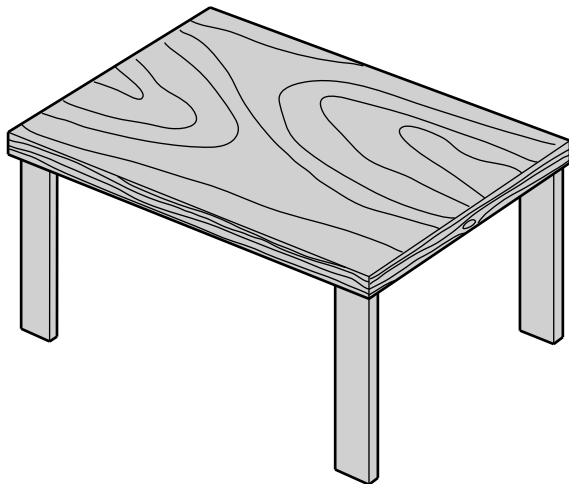
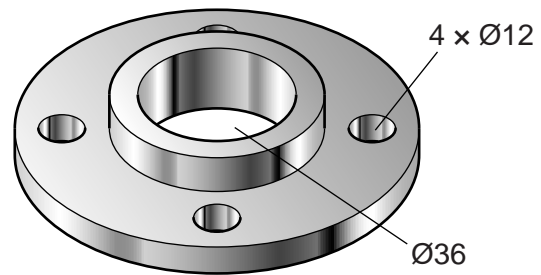

item: table top
process: edged and veneered

Fig. 1

Choose **two** of the items shown in Fig. 1 and for each:

(a) use notes and sketches to describe the manufacturing process named; [7 × 2]

(b) explain why the process is particularly suitable for the production of the item. [3 × 2]

3

2 Fig. 2 shows a door handle component.

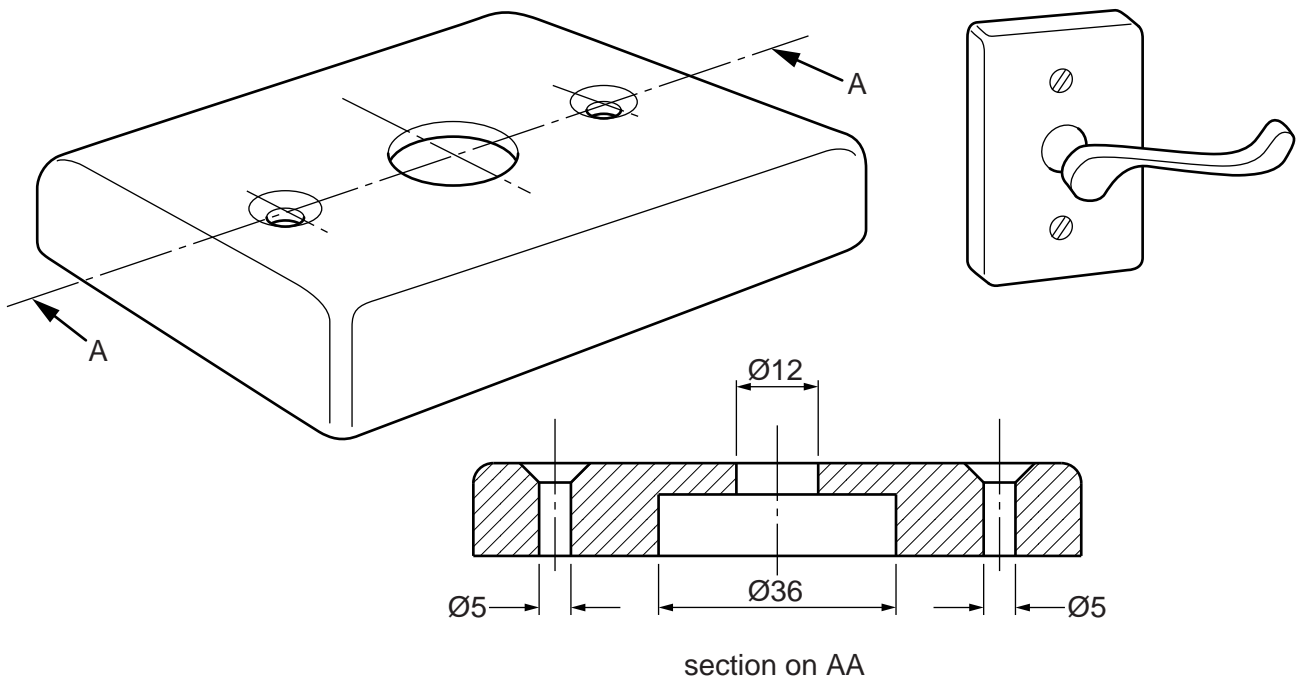

Fig. 2

- (a) State a suitable material for the door handle component and give **two** reasons for your choice. [3]
- (b) Describe, using notes and sketches, how you would make a single door handle component. [9]
- (c) Explain the changes which may be necessary to the design, the manufacturing method used and in the material selected if 5000 components were required. Use notes and sketches to support your answer. [8]

3 Fig. 3 shows a mobile phone.



Fig. 3

- (a) Explain, using notes and sketches where appropriate, **four** examples of where ergonomics will have influenced the design of a mobile phone of the type shown in Fig. 3. [12]
- (b) Discuss how advances of technology have impacted upon the design of a mobile phone. [8]

Part B – Practical Technology

- 4 (a) Name and explain the working of the following.
Use notes and sketches to support your answer and give an application in each case.
- (i) a type of switch [4]
 - (ii) a component that is used to sense changes in temperature [4]
 - (iii) a component that is used to sense changes in light [4]
- (b) Explain, using **two** applications, the function of a digital-to-analogue converter. [8]

- 5 Fig. 4 shows part of the frame of a bed made from softwood.

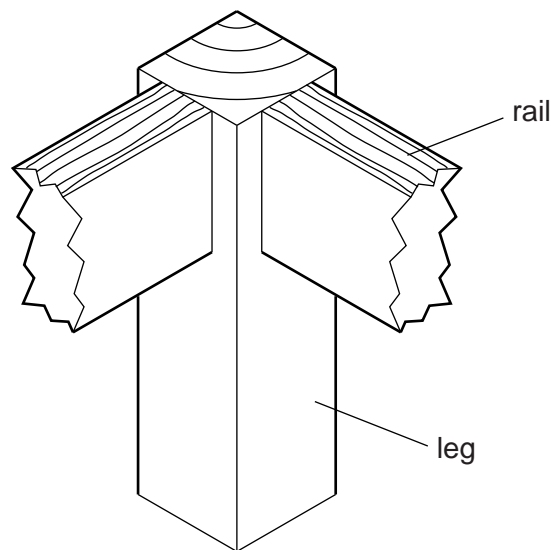

Fig. 4

- (a) Sketch and label **two** different joints which could be used to permanently join a rail to the leg. [6]
- (b) Sketch and label **two** different ways of joining a rail to the leg using KD (knock-down fittings). [6]
- (c) Discuss the benefits to the manufacturer of self-assembly products. [8]
- 6 (a) Give an example of:
- (i) a natural structure [1]
 - (ii) a man-made structure [1]
- (b) Give an example of each, and use notes and sketches, to compare a *monocoque* with a *frame* structure. [8]
- (c) (i) Describe what is meant by the terms *strut* and *tie*. [4]
- (ii) Use notes and sketches to explain how structures can be made to be more rigid. [6]

Part C – Graphic Products

7 Fig. 5 shows orthographic views of a barbecue area in a garden.

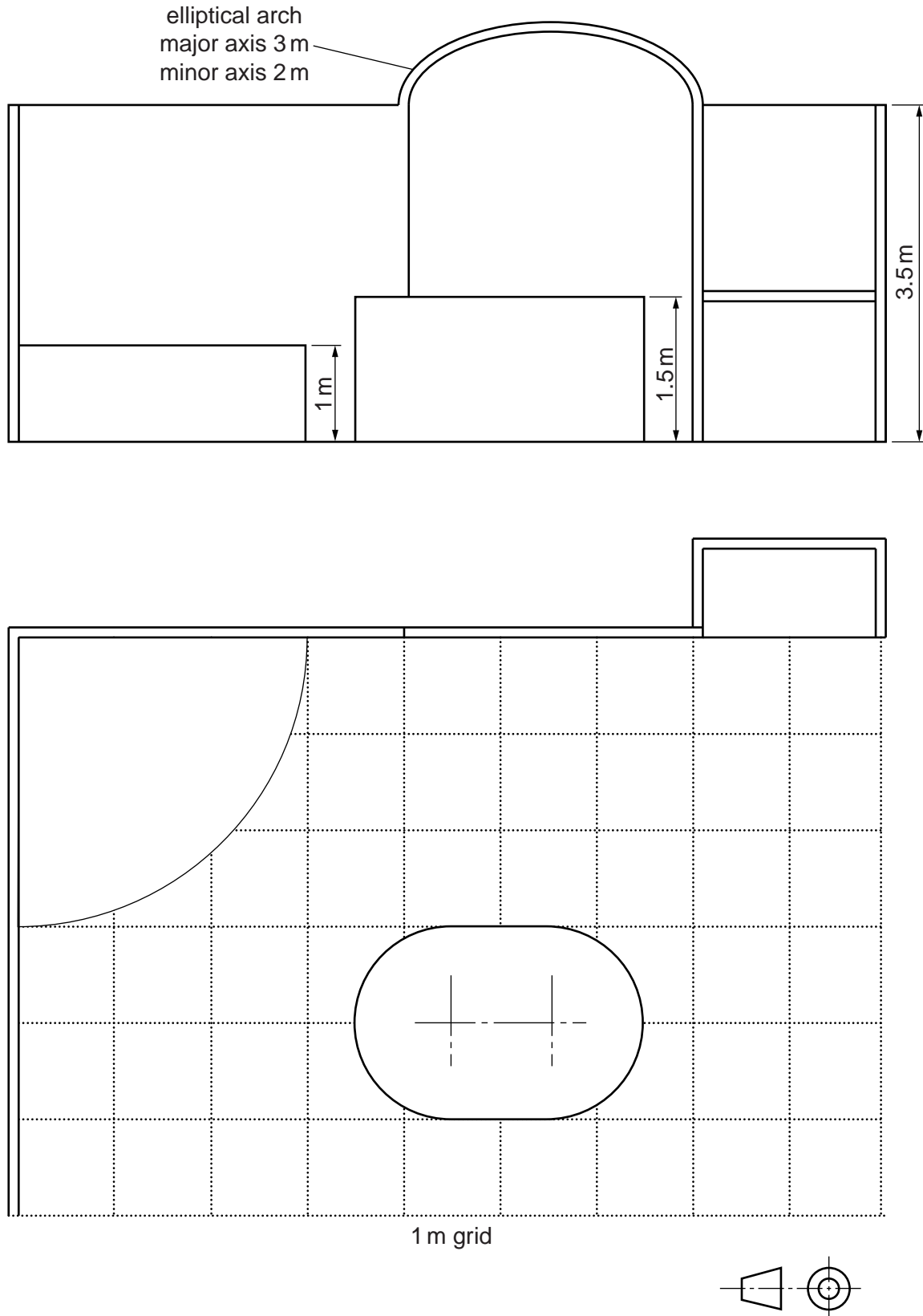

Fig. 5

Draw to an approximate scale, a planometric view of the barbecue area.

[20]

- 8 Fig. 6 shows a mouse mat, which is a promotional gift from a computer game company.

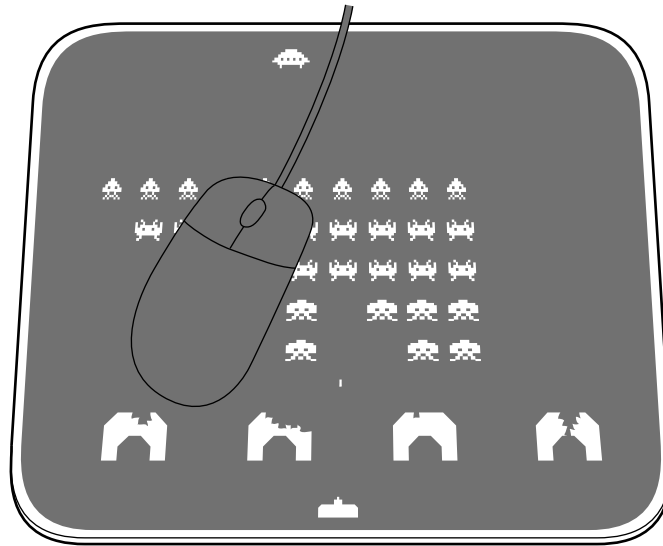

Fig. 6

- (a) State a suitable material for the mouse mat and give **two** reasons for your choice. [3]
- (b) Describe in detail the print method used on a batch of 5000 mouse mats. [7]
- (c) Discuss the environmental and ethical implications of using promotional gifts as part of a marketing strategy. [10]

9 Fig. 7 shows the packaging for a printer ink cartridge.

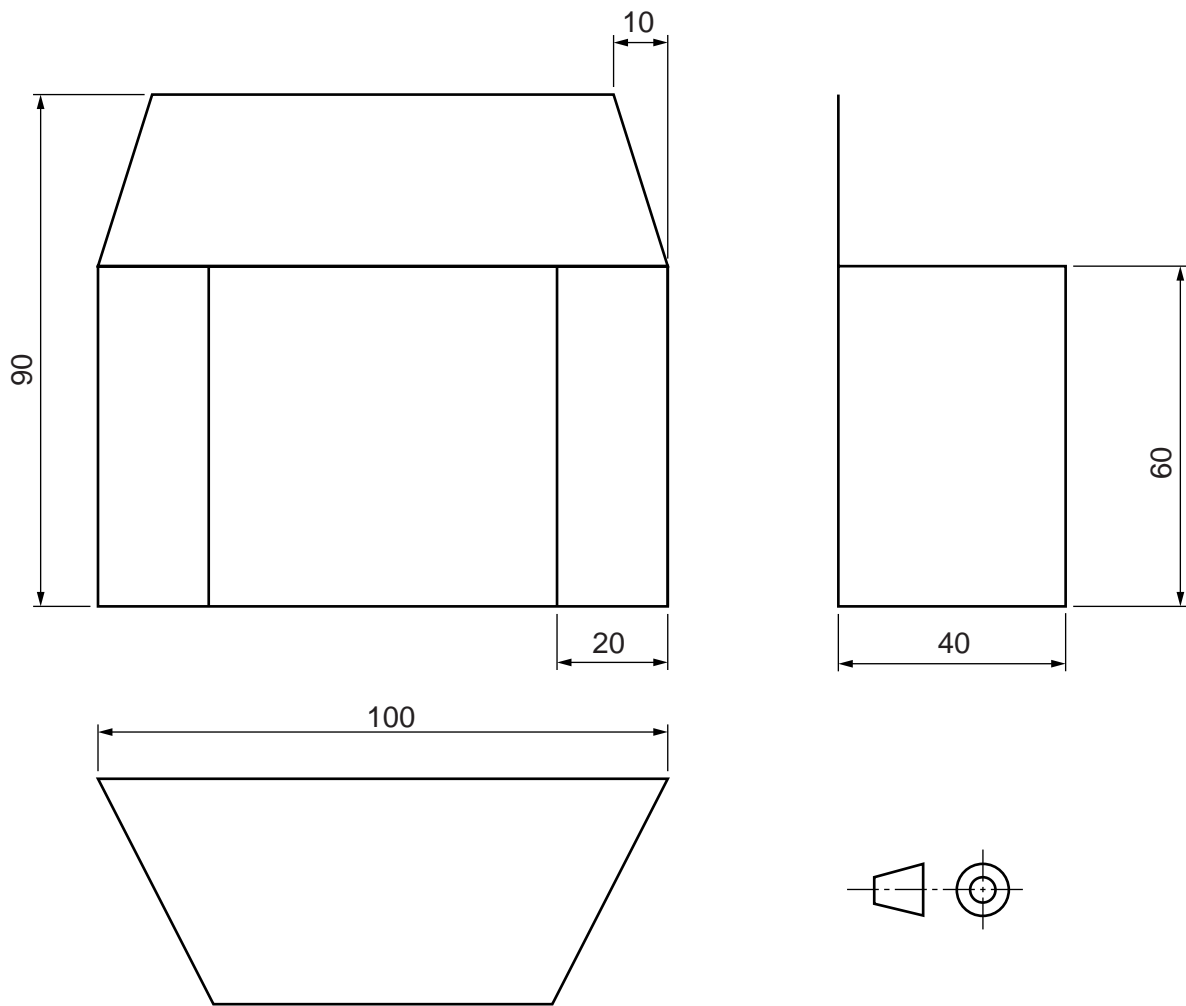

Fig. 7

- (a) Draw a full-size development of the printer cartridge package. Include all glue tabs. [10]
- (b) The package would be cut out from flat board using a die cutter. Use notes and sketches to describe in detail, the process of die cutting and creasing the package. [10]

Section B

Answer **one** question on the A3 paper provided.

You should approach the design question of your choice in the following manner:

Analysis

Produce an analysis of the given situation/problem, which may be in written or graphical form. [5]

Specification

From the analysis produce a detailed written specification of the design requirements.

Include at least five specification points other than those given in the question. [5]

Exploration

Use bold sketches and brief notes to show your exploration of ideas for a design solution, with reasons for selection. [25]

Development

Show, using bold sketches and notes, the development, reasoning and composition of ideas into a single design proposal. Give details of materials, constructional and other relevant technical details. [25]

Proposed solution

Produce drawings of an appropriate kind to show the complete solution. [15]

Evaluation

Give a written evaluation of the final design solution. [5]

[Total: 80]

- 10** Many students have limited space at home to do homework. You are to design a product that will enable students to do homework in their bedroom.

The product must:

- have a work surface that can be set at different angles;
- be easily stored when not in use.

To assist you in your answer, anthropometric data is given in Fig. 8.

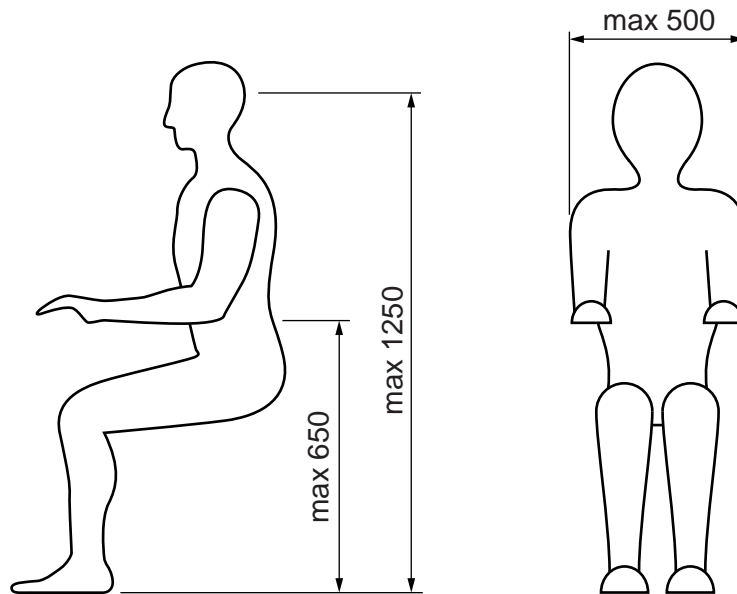

Fig. 8

- 11** A new school has a long driveway from the front gates to the school entrance. The driveway has no lighting and can be dangerous for students, teachers and visitors when dark.

You are to design a product that will give out light when lighting conditions fade. A number of these products would be required to illuminate the driveway.

The product must:

- be securely fixed;
- have its own power supply as mains electricity is not available on the driveway.

12 A new school requires a study area for senior students.

You are to design a model of a study area that allows for a maximum of 20 students. Present your proposed solution as a three-dimensional sketch of the model.

The area must provide:

- access to resources such as books, magazines and computers;
- flexibility in the layout of resources and furniture.

Details of the floor space of the area are given in Fig. 9.

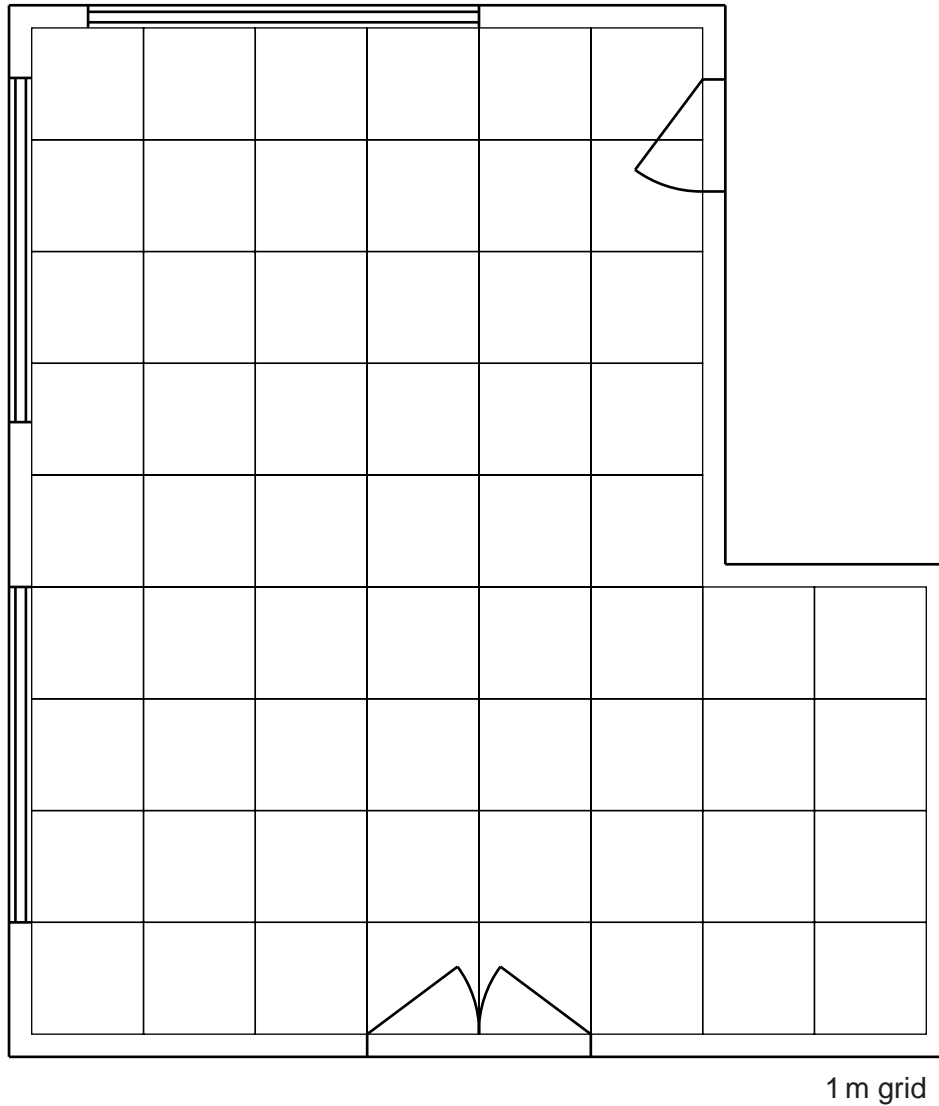

Fig. 9

BLANK PAGE

Permission to reproduce items where third-party owned material protected by copyright is included has been sought and cleared where possible. Every reasonable effort has been made by the publisher (UCLES) to trace copyright holders, but if any items requiring clearance have unwittingly been included, the publisher will be pleased to make amends at the earliest possible opportunity.

University of Cambridge International Examinations is part of the Cambridge Assessment Group. Cambridge Assessment is the brand name of University of Cambridge Local Examinations Syndicate (UCLES), which is itself a department of the University of Cambridge.