



UNIVERSITY OF CAMBRIDGE INTERNATIONAL EXAMINATIONS
General Certificate of Education Advanced Level

DESIGN AND TECHNOLOGY

9705/32

Paper 3

October/November 2012

3 hours

Additional Materials: Answer Booklet/Paper
A range of design drawing equipment
A3 Drawing Paper (5 sheets)



READ THESE INSTRUCTIONS FIRST

Write your Centre number, candidate number and name on all the work you hand in.

Write in dark blue or black pen.

You may use a soft pencil for any diagrams, graphs or rough working.

Do not use staples, paper clips, highlighters, glue or correction fluid.

Section A

Answer any **two** questions from **one** of the Parts **A**, **B** or **C**.

Section B

Answer **one** question.

All dimensions are in millimetres.

The instruction 'discuss' denotes that you should:

- examine critically the issues raised by the question;
- explain and interpret these issues as appropriate;
- introduce evidence wherever possible to support conclusions of arguments.

At the end of the examination, fasten all your work securely together.

The number of marks is given in brackets [] at the end of each question or part question.

This document consists of **9** printed pages and **3** blank pages.



Section A

Answer **two** questions from **one** of the Parts **A**, **B** or **C**.

Part A – Product Design

1

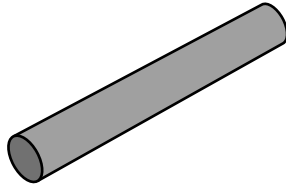

item: section of tube
process: extrusion

item: water cooler bottle
process: blow moulding

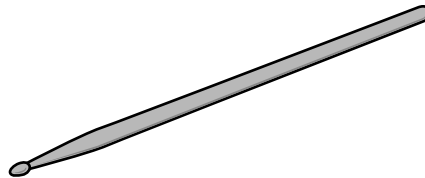
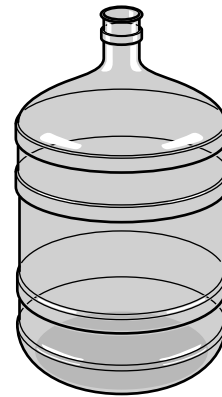

item: drum stick
process: turning

Fig. 1

Choose **two** of the items shown in Fig. 1 and for each:

- (a) use notes and sketches to describe the manufacturing process named; [7 × 2]
- (b) explain why the process is particularly suitable for the production of the item. [3 × 2]

2 (a) Use labelled sketches to describe the cutting action of **two** of the following tools:

- cross-cut saw;
- smoothing plane;
- drill bit.

[5 × 2]

(b) Use sketches and notes to describe in detail how the cutting edges of the **two** tools selected in part (a) are maintained. [5 × 2]

3 Fig. 2 shows a holder for salt and pepper pots.

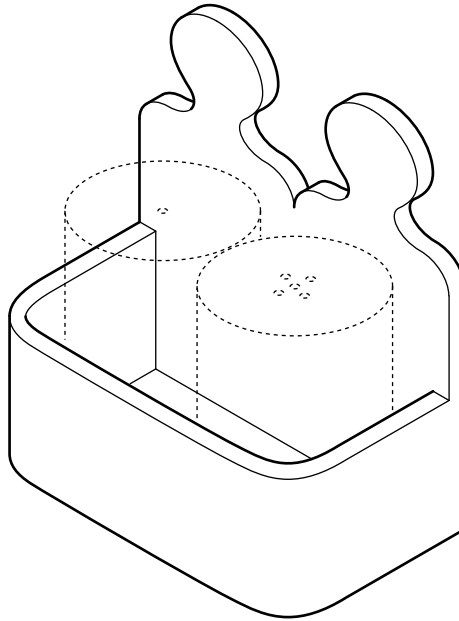

Fig. 2

(a) State a suitable material for the holder of the type shown in Fig. 2 and give **two** reasons for your choice. [3]

(b) Describe, using notes and sketches, how you would make the holder. [9]

(c) Explain what changes may be necessary to the design, in the manufacturing method used and in the material selected, if 50 holders were required. Use notes and sketches to support your answer. [8]

Part B – Practical Technology

- 4 (a) (i) Calculate the resistance in a circuit if the voltage is 12V and the current is 3A. [2]
- (ii) Calculate the current in a circuit if the voltage is 9V and the resistance is 40Ω. [3]
- (iii) Calculate the voltage required for a circuit if the resistance is 30kΩ and the current is 150μA. [3]
- (b) Discuss the impact of rapid advances in electronics on the design of products. [12]
- 5 Many products include one or more mechanisms.
Select a different product for each of the following and use notes and sketches to describe the working principles of the mechanism.
- (a) crank; [5]
- (b) linkage; [5]
- (c) cam; [5]
- (d) worm and worm wheel. [5]
- 6 Engineers and product designers have to consider the environment in which a product is to be used before making decisions on the choice of material.
- (a) State **two** different specific materials that are appropriate for use in outdoor environments. For each, describe the properties that make it suitable for use outdoors. [6]
- (b) Describe in detail how **one** specific wood and **one** specific metal can be treated to extend their useful life in outdoor environments. [8]
- (c) Explain the benefits of alloying to an engineer or product designer. [6]

Part C – Graphic Products

7 Fig. 3 shows a trophy to be awarded for achievement in school sport.

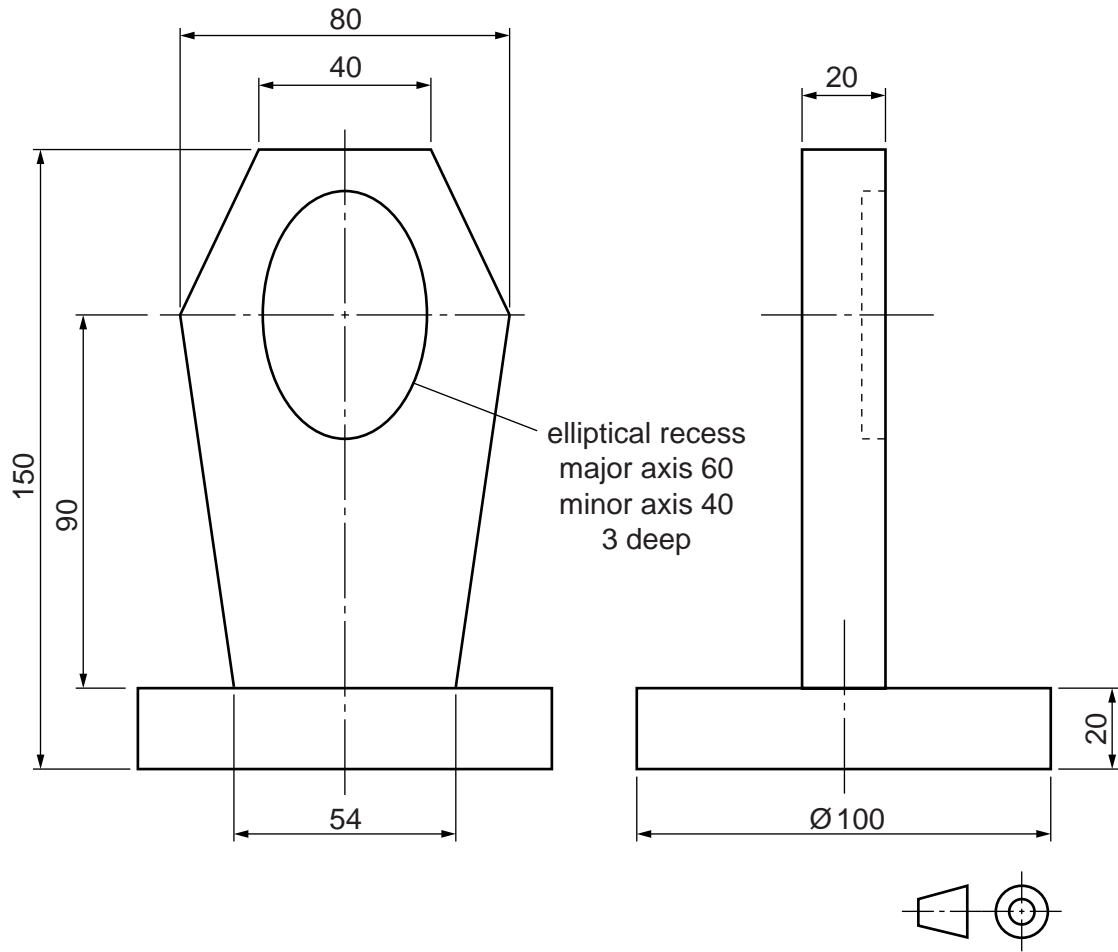

Fig. 3

Draw a full-size isometric view of the trophy.

[20]

8 A major issue for manufacturing companies is the time it takes for new products to be developed and launched on the market. This is often referred to as 'lead time'. Discuss how companies are reducing 'lead time' in terms of:

- quality control;
- manufacturing methods used;
- increased use of CAD/CAM.

[20]

- 9 Fig. 4 shows part of a drawing for the case of a computer-game controller.

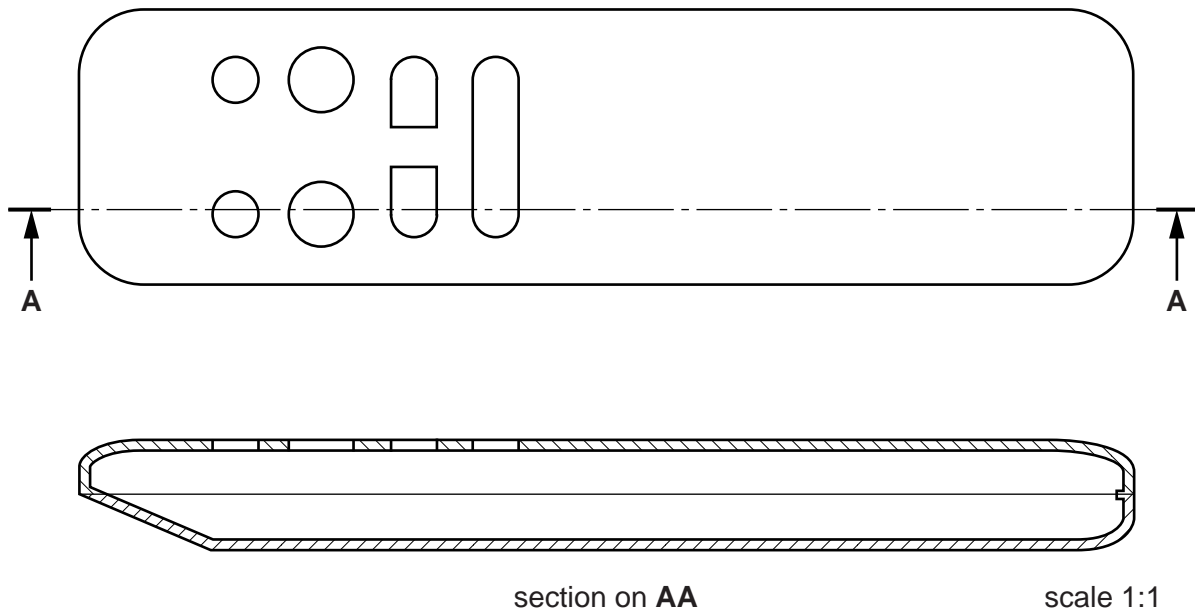

Fig. 4

- (a) (i) Name the specific type of drawing shown. [2]
- (ii) Explain, giving **two** reasons, why this type of drawing is the preferred choice for the production of components. [4]
- (b) Describe **two** examples where anthropometric data has influenced the design of a computer-game controller. Use notes and sketches to support your answer. [6]
- (c) Discuss the importance of target markets when developing a marketing campaign for computer games. [8]

Section B

Answer **one** question on the A3 paper provided.

You should approach the design question of your choice in the following manner:

Analysis

Produce an analysis of the given situation/problem, which may be in written or graphical form. [5]

Specification

From the analysis produce a detailed written specification of the design requirements.

Include at least five specification points other than those given in the question. [5]

Exploration

Use bold sketches and brief notes to show your exploration of ideas for a design solution, with reasons for selection. [25]

Development

Show, using bold sketches and notes, the development, reasoning and composition of ideas into a single design proposal. Give details of materials, constructional and other relevant technical details. [25]

Proposed solution

Produce drawings of an appropriate kind to show the complete solution. [15]

Evaluation

Give a written evaluation of the final design solution. [5]

[Total: 80]

10 A school has limited space indoors for students to eat lunch.

You are to design a product that would enable students to be seated and eat their lunch outdoors.

The product must:

- be able to seat a maximum of four students.
- be able to be moved and stored easily.

To assist you in your answer, anthropometric data is given in Fig. 5.

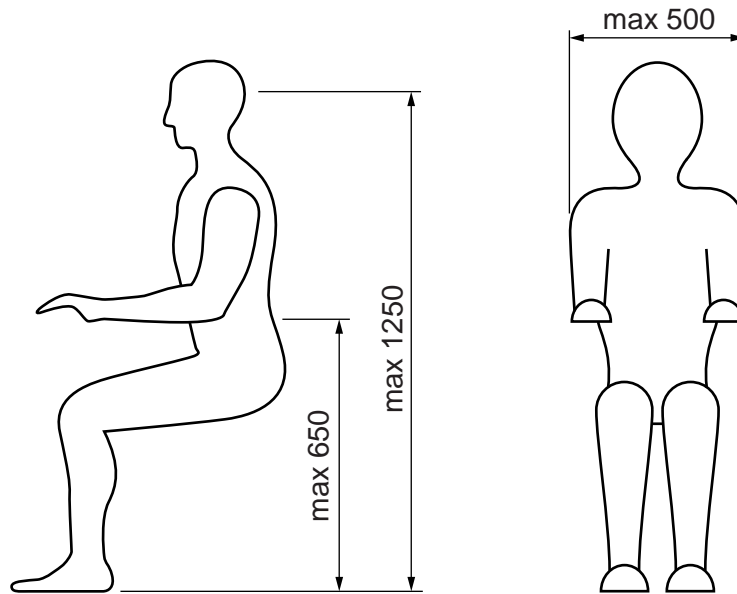

Fig. 5

- 11** Many storekeepers have difficulty in reaching and selecting products from high shelves in their stores.

You are to design a device that will help the storekeeper to retrieve products from high shelves.

The device must:

- be hand-held;
- hold the items securely when retrieving or returning products.

The maximum size of products is given in Fig. 6.

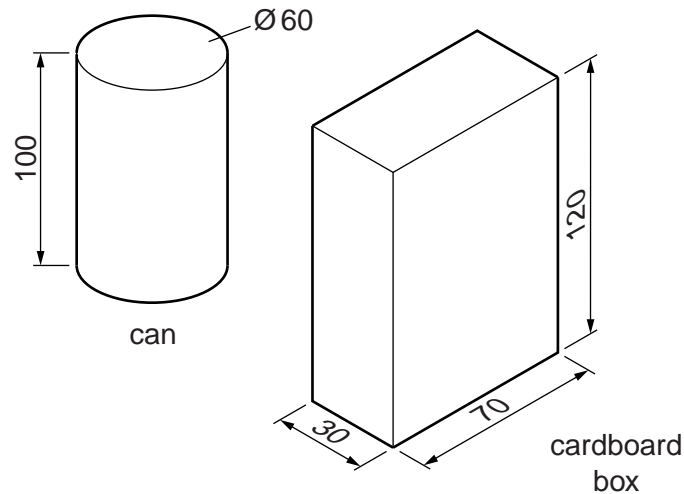

Fig. 6

- 12** A company wishes to extend its range of celebration cards. There is a need for more unique and elaborate cards for specialist or one-off events.

You are to design a card to celebrate the opening of a new shop of your choice.

The card must:

- have a 'pop-up' or interactive feature;
- reflect the business of the shop.

BLANK PAGE

Permission to reproduce items where third-party owned material protected by copyright is included has been sought and cleared where possible. Every reasonable effort has been made by the publisher (UCLES) to trace copyright holders, but if any items requiring clearance have unwittingly been included, the publisher will be pleased to make amends at the earliest possible opportunity.

University of Cambridge International Examinations is part of the Cambridge Assessment Group. Cambridge Assessment is the brand name of University of Cambridge Local Examinations Syndicate (UCLES), which is itself a department of the University of Cambridge.