

UNIVERSITY OF CAMBRIDGE INTERNATIONAL EXAMINATIONS
GCE Advanced Subsidiary Level and GCE Advanced Level

**MARK SCHEME for the October/November 2010 question paper
for the guidance of teachers**

9705 DESIGN AND TECHNOLOGY

9705/32

Paper 3, maximum raw mark 120

This mark scheme is published as an aid to teachers and candidates, to indicate the requirements of the examination. It shows the basis on which Examiners were instructed to award marks. It does not indicate the details of the discussions that took place at an Examiners' meeting before marking began, which would have considered the acceptability of alternative answers.

Mark schemes must be read in conjunction with the question papers and the report on the examination.

- CIE will not enter into discussions or correspondence in connection with these mark schemes.

CIE is publishing the mark schemes for the October/November 2010 question papers for most IGCSE, GCE Advanced Level and Advanced Subsidiary Level syllabuses and some Ordinary Level syllabuses.

Page 2	Mark Scheme: Teachers' version	Syllabus	Paper 1
	GCE A/AS LEVEL – October/November 2010	9705	

Section A

Part A – Product Design

- 1 (a) Appropriate material including:
- Aluminium/brass/pewter/silver
 - Acrylic/polyester resin
 - Any attractive hardwood e.g. ebony (1)
- Reasons including:
- takes a good finish
 - good aesthetic qualities,
 - will not irritate skin (2 × 1) [3]
- (b) Description to include:
- appropriate method;
 - piercing/shaping/casting
- Quality of description:
- some detail (0–2)
 - fully detailed (3–7)
- Quality of sketches (up to 2) [9]
- (c) Explanation could include:
- change in process;
 - change in materials;
 - use of jigs, formers, moulds;
 - simplification of design.
- Quality of explanation:
- limited detail (0–3)
 - logical, structured (4–6)
- Quality of sketches (up to 2) [8]
- [Total: 20]**

Page 3	Mark Scheme: Teachers' version	Syllabus	Paper 1
	GCE A/AS LEVEL – October/November 2010	9705	

- 2 (a) Description of process
- some detail (0–2)
 - fully detailed (3–5)
- Quality of sketches (up to 2) [7 × 2]
- (b) Blow moulding
- accurate repetitive production
 - large numbers produced
 - even wall thickness
 - no need for extra finishing process
- Shaping and joining
- difficult to produce in one piece
 - prevents waste
 - strong construction
 - complex shapes formed
- Milling
- profile cutter for radius, slot cutter and face finishing
 - quick
 - accurate finish [3 × 2]
- [Total: 20]**
- 3 Discussion could include:
- Cultural implications
- avoid offence
 - target needs of tourist
 - product could have cultural value
- Economic issues
- pricing/promotion/placement strategies
 - value for money
 - support local economy
- Examples/evidence could be
- symbols/religion
 - cultural/historical value e.g. Dodo
 - size of product/packaging
 - recycled materials or protected species (e.g. timber/fur)
- Examination of issues
- limited range (0–3)
 - wide range of relevant issues (4–8)
- Quality of explanation
- limited detail (0–3)
 - logical, structured (4–8)
- Supporting examples/evidence (4) [20]
- [Total: 20]**

Page 4	Mark Scheme: Teachers' version	Syllabus	Paper 1
	GCE A/AS LEVEL – October/November 2010	9705	

Part B – Practical Technology

4	(a) AC or AB compression	(1)	
	BC in tension	(1)	[2]
	(b) $30 \times 5 + 25 \times 2 = 200$	(1)	
	$200/5 = 40\text{N}$	(1)	[2]
(c)	Explanation monocoque (one piece)	(2)	
	example e.g. airplane, egg	(1)	
	explanation frame (several components)	(2)	
	example e.g. chair, building	(1)	[6]
(d)	Discussion could include:		
	<ul style="list-style-type: none"> • regular usage • extreme conditions/shrinkage/expansion • material change 		
	Examination of issues		
	<ul style="list-style-type: none"> • limited range • wide range of relevant issues 	(0–2)	
	Quality of explanation		
	<ul style="list-style-type: none"> • limited detail • logical, structured 	(0–1)	
	Supporting examples/evidence	(2)	[10]
			[Total: 20]

Page 5	Mark Scheme: Teachers' version	Syllabus	Paper 1
	GCE A/AS LEVEL – October/November 2010	9705	032Based.com

- 5 (a) $\frac{B}{A} \times \frac{D}{C}$ (1)
- $\frac{40}{20} \times \frac{30}{10} = 6$ (1)
- gear ratio 6:1 (1) [3]

(b) (i)

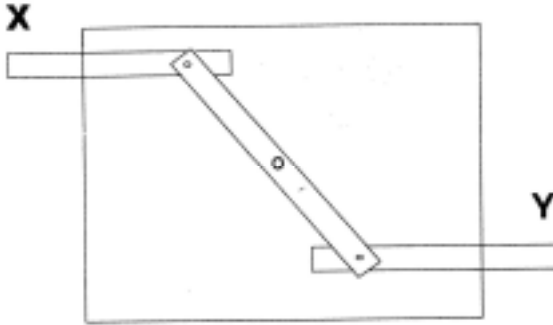

[2]

(ii)

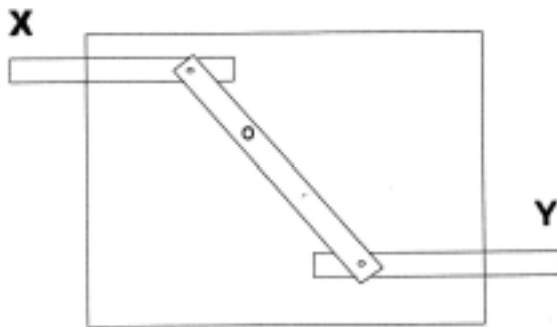

[3]

- (c) explanation of mechanical example (2)
 explanation of pneumatic example (1)
- explanation of pneumatic example (2)
 explanation of hydraulic example (1)
- explanation of hydraulic example (2)
 explanation of hydraulic example (1)
- comparisons (up to 3) [12]

[Total: 20]

Page 6	Mark Scheme: Teachers' version	Syllabus	Paper 1
	GCE A/AS LEVEL – October/November 2010	9705	

- 6 (a) Appropriate material including:
- zinc
 - polystyrene
- [1]
- Reasons including:
- easily cast
 - takes complex shapes
 - can be finished
- (2 × 1) [2]
- (b) Description to include:
- appropriate method;
 - injection moulding
 - die casting
- Quality of description:
- some detail (0–2)
 - fully detailed (3–5)
- Quality of sketches (up to 2) [7]
- (c) Discussion could include:
- CNC CAD control – automated machines
 - accurate/repetitive production
 - quality control potential
- Examination of issues
- limited range (0–2)
 - wide range of relevant issues (3–5)
- Quality of explanation
- limited detail (0–1)
 - logical, structured (2–3)
- Supporting examples/evidence (2) [10]
- [Total: 20]**

Page 7	Mark Scheme: Teachers' version	Syllabus	Paper 1
	GCE A/AS LEVEL – October/November 2010	9705	

Part C – Graphic Products

7 (a)	Discussion could include:		
	<ul style="list-style-type: none"> genuine need/target market affordability/quality sale introductory offers market accessibility 		
	Examples/evidence could be		
	<ul style="list-style-type: none"> teenage/adult market tourist sites BOGOF 		
	Examination of issues		
	<ul style="list-style-type: none"> limited range wide range of relevant issues 	(0–3) (4–8)	
	Quality of explanation		
	<ul style="list-style-type: none"> limited detail logical, structured 	(0–3) (4–8)	
	Supporting examples/evidence	(4)	[20]
			[Total: 20]
8 (a)	Correct front sectional view	(6)	
	Correct plan	(4)	
	Scale	(1)	
	Accuracy quality of line-work	(5)	[16]
(b)	Appropriate ways e.g., knurling, shaping	(2 × 2)	[4]
			[Total: 20]
9 (a)	correct perspective	(3)	
	approx twice full size	(2)	
	quality of linework	(3)	
	overall shape/proportion	(6)	[14]
(b)	rendering		
	roof	(2)	
	walls	(2)	
	other feature	(2)	[6]
			[Total: 20]